

Desigo™

System controller

PXC5.E003



System controller for integration of BACnet/MSTP, Modbus, and KNX PL-Link devices

- System controller to integrate BACnet MS/TP, Modbus, and KNX PL-Link devices
- BACnet/IP communication (BTL certified)
- BACnet Secure Connect communication
- 2-port Ethernet switch for low-cost cabling
- KNX PL-Link bus to connect RDG2..KN room thermostats, sensors, and operator units (including bus power)
- Integration of M-bus energy meters directly (integrated mini power supply) or via RS485 level-converter
- Integration of Modbus data points via RTU and / or TCP
- Integration of BACnet MS/TP devices
- WLAN interface for engineering and commissioning
- Operating voltage AC or DC 24 V
- Mounted on standard rails or on the wall
- Plug-in screw terminal blocks
- Building X integration

Freely programmable system controller.

- System functions (alarming, scheduling, trending, access protection with individually definable user profiles and categories)
- System controller for system networks with PXC3, PXC4, PXC5, PXC7 and DXR controllers over BACnet/IP, BACnet/SC, or BACnet MS/TP
- Integrates third-party devices and systems
- Integration of wired M-bus meters via RS485 level-converter or onboard M-bus interface (EN 13757-2):
 - Offline and/or online engineering with ABT Site. No additional M-bus tool required
 - Primary and/or secondary device addressing
- The following functions are available with KNX PL-Link bus:
 - Communication with RDG2..KN room thermostats, sensors, and operator units
 - Plug-and-play connection of Siemens field devices with KNX PL-Link
- Generic object viewer for data points of several assigned devices via embedded web interface
- Generic object viewer for local data points and assigned devices via embedded web interface
- Engineering and commissioning with the ABT Site Tool using graphical function charts
- BTL tested BACnet communication on IP (BACnet/IP and BACnet/SC) or MS/TP, in compliance with the BACnet standard including B-BC profile (Rev. 1.16)
- IT security including HTTPS, IEC-62443 4-2 (Security Level 2*), and BACnet Secure Connect
- BACnet Secure Connect support as BACnet/SC hub
- Wireless connection for engineering and commissioning
- Cloud connectivity to Building X for remote access and data points time series
- Integration of Modbus data points via RTU and / or TCP
- DIN rail or screw mounting
- Plug-in screw terminal blocks

* For details about network and physical setup, refer to the [Desigo Cybersecurity Guidelines](#).

Type summary

Type	PXC5.E003
Order number	S55375-C103 ¹⁾
Number of integration data points (M-bus + Modbus TCP + Modbus RTU)	up to 500
Number of digital inputs for potential-free contacts for signaling functions NO or NC (onboard)	1
Number of BACnet/MSTP devices per RS485 interface	up to 60 ²⁾
Number of BACnet/SC devices as a BACnet/SC hub	up to 100
Number of KNX PL-Link devices	up to 64
Number of configurable field level networks per RS485 (either for Modbus RTU, BACnet MS/TP or M-bus level converters with maximum of 250 meters each)	2
Number of M-bus meters wired via level converters (RS485) ³⁾	2 x 250

¹⁾ For details on engineering, see PXC4, PXC5 & PXC7 Planning overview, [A6V13054435](#).

²⁾ Depending on the behavior of the third-party MS/TP devices.

³⁾ The limitation is given by the maximum number of integration data points and maximum number of BACnet objects.

Onboard inputs

DI	Digital inputs for potential-free contacts for signaling functions (NO, NC)
----	---

KNX PL-Link devices

Description	Type	Data sheet
Wall-mounted temperature sensor	QMX3.P30	CM2N1602
Wall-mounted temperature and humidity sensor	QMX3.P40	
Wall-mounted temperature, humidity, and CO ₂ sensor	QMX3.P70	
Wall-mounted temperature sensor and room operator unit	QMX3.P34	
Wall-mounted temperature and humidity sensor and room operator unit	QMX3.P44	
Wall-mounted temperature, humidity, and CO ₂ sensor and room operator unit	QMX3.P74	
Wall-mounted temperature sensor and room operator unit	QMX2.P33	A6V10733768
Wall-mounted temperature and humidity sensor and room operator unit	QMX2.P43	
Flush-mounted room sensors base and front modules: <ul style="list-style-type: none"> • Base module for temperature and / or humidity measurement ¹⁾ • Base module for CO₂ measurement ¹⁾ • Front module for base module without sensor • Front module for base module with temperature sensor • Front module for base module with humidity and temperature sensor • Front module for base module with humidity, temperature sensor, and CO₂ indicator LED 	<ul style="list-style-type: none"> • AQR2570 • AQR2576 • AQR2530NNW • AQR2532NNW • AQR2535NNW • AQR2535NNWQ 	CE1N1411
Passive infrared presence detector	UP 258D12	A6V10489489
Presence detector WIDE with temperature sensor	UP 258D31	A6V11894530
Presence detector WIDE with temperature and humidity sensor	UP 258D41	
Presence detector WIDE with temperature, humidity, and CO ₂ sensor	UP 258D51	
Presence detector WIDE with temperature sensor and ultrasound	UP 258D61	
Room thermostat with temperature and humidity sensor	RDG200KN RDG260KN	A6V11545853
Room thermostat with temperature, humidity, and CO ₂ sensor	RDG204KN RDG264KN	

¹⁾ Physical data points on the base module AQR257.. for use in HVAC functions:
- 2 x Binary potential-free contacts (NO, NC)
- 1 x Passive sensor NTC10K (Type II / Beta (0-50 °C) = 3892 K)
For details see PXC4, PXC5 & PXC7 Planning overview [A6V13054435](#) and data sheets.

Desigo Control Point



Description	Type	Data sheet
BACnet touch panels with integrated data storage and web server functionality: 7.0 " 10.1 " 15.6 "	PXM30.E PXM40.E PXM50.E	A6V11664137
TCP/IP client touch panels with data storage in web server PXG3.Wx00-2: 7.0 " 10.1 " 15.6 "	PXM30-1 PXM40-1 PXM50-1	A6V11664139
BACnet/IP web server with standard functionality BACnet/IP web server with extended functionality	PXG3.W100-2 PXG3.W200-2	A6V12304192

Technical and mechanical design

The compact build allows for mounting the devices on a standard rail or a wall.

		4	Service button (network login and WLAN on/off)		
		5	2-port Ethernet switch with 2 LEDs per port for display purposes		
		6	Plug-in terminal block with screw terminals KNX PL-Link		
		7	Plug-in terminal block with screw terminals Power supply		
		8	Plug-in terminal blocks with screw terminals Digital input		
		9	Plug-in terminal block with screw terminals M-bus		
		10	Plug-in terminal block with screw terminals COM1 / COM2 (Mbus, MS/TP, or Modbus)		
		11	DIP switches for bus termination and polarization COM1 / COM2		
		12	Slider for mounting on standard mounting rails		
		13	Eyelets for cable ties		
		14	Holes for wall mounting		
		15	Date / Series and Serial number		
		16	QR code for default WLAN access Description see Technical data		
		1	Plastic housing		
		2	Front cover		
		3	LEDs for communication and state		

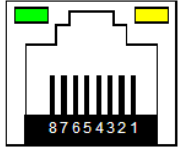
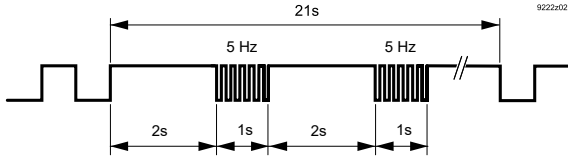
LED displays

Activity	LED	Color	Activity	Function
 8 7 6 5 4 3 2 1 927/02/05 ■ RUN ■ COM1 TX ■ COM1 RX ■ BAT ■ COM2 TX ■ KNX ■ COM2 RX ■ SVC ■ WLAN	Ethernet 1/2	Green	Continuously ON Continuously OFF Flashing	Link active No connection Network traffic
		Yellow	Continuously ON Continuously OFF	Link 100 Mbps Link 10 Mbps
	RUN	Green	Continuously ON Continuously OFF Flashing	Device operational Device not operational Start-up or program halted
		Red	Continuously OFF Continuously ON Rapid flashing	OK HW or SW fault Firmware or application missing/corrupted
	☁	Blue	Steady ON Blinking Steady OFF	Cloud connection OK Cloud connection enabled but no connection available Cloud connection disabled
	BAT	Red	Continuously OFF Continuously ON	Optional battery OK Optional battery empty - replace
	COM...	Yellow	Flashing Continuously OFF	Communication No communication to subsystem
	KNX	Yellow	Flashing Continuously OFF	Communication No communication to subsystem
	SVC	Red	Continuously OFF Flashing	OK Device is not configured
				Flashing per wink command
			 9222/02	
	WLAN	Blue	Steady OFF Steady ON Flashing	WLAN inactive WLAN active and at least one WLAN client connected WLAN active and no WLAN client connected
 SVC	Service button		Press 0.2 ... 1 s Press 1 ... 3 s	Identification in the network Enable/disable WLAN WLAN is disabled automatically after 10 min if no client is connected
			As per description	Do the following to reset the device to factory state: <ol style="list-style-type: none"> 1. Power off the device. 2. Power on the device. 3. Wait until all LEDs light up and turn off again, then press the Service button. 4. Keep the Service button pressed until all LEDs light up, then release the button. All LEDs go off, the device restarts. 5. Wait until the device has fully started – unconfigured (green RUN LED and red SVC LED are flashing)

Product documentation

Related documents such as the environmental declarations, declarations of conformity, etc., can be downloaded from the following Internet address:

www.siemens.com/bt/download

Notes

Safety



 CAUTION	
	<p>National safety regulations</p> <p>Failure to comply with national safety regulations may result in personal injury and property damage.</p> <ul style="list-style-type: none">• Observe national provisions and comply with the appropriate safety regulations.

Mounting position and ambient temperature

The devices can be snapped onto standard rails or screwed onto a flat surface. Plug-in screw terminals connect power and interfaces.

Ambient temperature -5...50 °C (23...122 °F)	Ambient temperature -5...45 °C (23...113 °F)
<ul style="list-style-type: none">• Wall, horizontal<ul style="list-style-type: none">– From left to right– From right to left	<ul style="list-style-type: none">• Overhead• Wall, vertically<ul style="list-style-type: none">– From top to bottom– From bottom to top• On a horizontal surface

Installation

 WARNING	
	<p>Electric shock</p> <p>Incorrect installation of the device may lead to electric shock injuries when touching the device!</p> <ul style="list-style-type: none">• Install the device in a lockable cabinet or use terminal covers.• Do not install the device in locations where children are likely to be present.• Conductors with a cross-section of 0.5 mm² (AWG24) or greater shall comply with the requirements of IEC 60332-1-2 and IEC 60332-1-3 or IEC TS 60695-11-21.

Disposal

	<p>This symbol or any other national label indicate that the product, its packaging, and, where applicable, any batteries may not be disposed of as domestic waste. Delete all personal data and dispose of the item(s) at separate collection and recycling facilities in accordance with local and national legislation.</p> <p>For additional details, refer to Siemens information on disposal.</p>
---	---

Warranty

The application-specific technical data is guaranteed only in combination with the Siemens products listed in the 'Device combinations' section. If third-party products are used, any guarantee provided by Siemens will be invalidated.

Technical data

Power supply

Operating voltage (24 V~, \perp , PE)	AC 24 V -15 / +20 % (PELV) AC 24 V Class 2 (US) 48...63 Hz
Operating voltage DC 24 V (24 V=, \perp , PE)	DC 24 V -15 / +20 % (PELV) DC 24 V Class 2 (US)
Functional ground (US) Functional earth PE	The terminal for the functional ground must be connected on the installation side with the building grounding system (PE).
Screw terminals for wire cross sections up to	Max. 2.5 mm ² (14 AWG)
Internal fusing	3.15 A irreversible / non-replaceable
External supply line fusing (EU)	Non-renewable fuse max. 10 A slow-blow or circuit breaker max. 13 A Tripping characteristic B, C, D per EN 60898 or Power supply with current limitation of max. 10 A
Protection	Reverse connection protection for DC 24 V

Power consumption (for transformer planning)

	Operating voltage AC 24 V	Operating voltage DC 24 V
Full load	19 VA / 0.8 A	8 W / 0.33 A
Base load (without loading by KNX PL-Link and M-bus)	12 VA / 0.5 A	3.3 W / 0.15 A
KNX PL-Link supply	4 VA / 0.17 A	2.2 W / 0.09 A
M-bus supply	3 VA / 0.13 A	1.7 W / 0.07 A

Function data

Hardware information	
Processor	NXP i.MX8 DualX, 1 GHz
Storage	1 GByte RAM 8 GByte eMMC

Data backup in the event of power failure
Energy reserve (supercapacitor) to support real-time clock (7 days). Energy reserve to support real-time clock can be extended using optional battery CR2032: depending on the life time of the battery and use, typically 10 years. <i>(Battery safety requirement and specification for CR2032 according to IEC 60086-4 or UL1642. Battery must be rated for ambient temperature 70 °C (158 °F))</i> Low power of battery will be indicated by LED and a system alarm will be generated
Data available if stored to flash memory: Every 5 minutes. The interval of 5 minutes is only valid for change log but not for trending. In case of a power failure, trend log data can be lost up to 30 minutes.

Ethernet interface	
Plug	2 x RJ45, shielded
Interface type	10Base-T / 100Base-TX, IEEE 802.3 compatible
Bit rate	10/100 Mbps, autosensing
Protocol	BACnet/IP on UDP/IP, BACnet/SC on TCP/IP, and HTTPS on TCP/IP
Cabling (in-house cabling only), cable type	10 Mbps: Min. CAT3, shielded cable is recommended 100 Mbps: Min. CAT5, shielded cable is recommended
Cable length	Max. 100 m (330 ft)

Screw terminals, plug-in	
Cu-wire or Cu-strand with wire end sleeve	1 x 0.6 mm \varnothing to 2.5 mm ² (22 to 14 AWG) or 2 x 0.6 mm \varnothing to 1.0 mm ² (22 to 18 AWG)
Cu-strand without wire end sleeve	1 x 0.6 mm \varnothing to 2.5 mm ² (22 to 14 AWG) or 2 x 0.6 mm \varnothing to 1.5 mm ² (22 to 16 AWG)
Stripping length	6...7.5 mm (0.24...0.29 in)
Screwdriver	Slot screws, screwdriver size 1 with shaft \varnothing = 3 mm
Max. tightening torque	0.6 Nm (0.44 lb ft)

The two COM interfaces can be used either for M-bus, Modbus RTU, or for BACnet MS/TP, according to configuration.

M-bus interface on COM interface (RS485)	
Interface type	EIA-485, electrically isolated
Baud rate	300, 600, 1200, 2400, 4800, 9600, 19200, 38400. The maximum baud rate is depending on the configuration of M-bus-S devices (subordinate devices) and M-bus repeater.
Internal bus termination	120 Ohm, switchable with DIP switch
Internal bus polarization	270 Ohm pull-up/pull-down resistances, switchable with DIP switch
Cabling (in-house cabling only) Cable length	3-wire cable, shielded cable recommended (shield must be connected to building earth in the mounting panel) Max. 1000 m (3300 ft)
Protection	Short-circuit proof Protection against faulty wiring with AC 24 V and DC 24 V
M-bus level converter including power supply (required)	Configuration examples (simple M-bus loads à 1.5 mA): <ul style="list-style-type: none"> • Up to 2 M-bus devices: STV Electronic, MPW-2 ¹ • Up to 6 M-bus devices: STV Electronic, MPW-6 ¹ • Up to 60 M-bus devices: Relay GmbH, PW60 ¹ • Up to 250 M-bus devices: Siemens, WTX631-GA0090

¹ For STV Electronic level converters, refer to <https://www.stv-electronic.de/>. For Relay GmbH level converters, refer to <https://www.relay.de/>.

The use of these products is a recommendation only. Siemens cannot guarantee functionality nor take over any warranty for third-party products. This information is subject to change without notice.

Modbus RTU interface	
Interface type	EIA-485, electrically isolated
Baud rate	300, 600, 1200, 2400, 4800, 9600, 19200, 38400, 57600, 76800, 115200 (depending on the configuration)
Internal bus termination	120 Ohm, switchable with DIP switch
Internal bus polarization	270 Ohm pull-up/pull-down resistances, switchable with DIP switch
Cabling (in-house cabling only) Cable length	3-wire cable, shielded cable recommended (shield must be connected to building earth in the mounting panel) Max. 1000 m (3300 ft)
Protection	Short-circuit proof Protection against faulty wiring with AC 24 V and DC 24 V

BACnet MS/TP interface	
Interface type	EIA-485, electrically isolated
Baud rate	9600, 19200, 38400, 76800, 115200 (depending on the configuration)
Internal bus termination	120 Ohm, switchable with DIP switch
Internal bus polarization	270 Ohm pull-up/pull-down resistances, switchable with DIP switch
Cabling (in-house cabling only) Distance between 2 devices Length of the MS/TP line	3-wire cable, shielded Max. 500 m (1650 ft) Max. 1000 m (3300 ft)
Protection	Short-circuit proof Protection against faulty wiring with AC 24 V and DC 24 V

WLAN interface	
Interface type	Wireless access point
Supported standards	IEEE 802.11b/g/n
Frequency band	2.4...2.462 GHz
WLAN channels	1...11
Maximum radio-frequency power	16.4 dBm
Distance (unobstructed field)	Min. 5 m (16 ft)
Device pairing	Activation / deactivation with service button Automatic switch off after 10 minutes if no WLAN-client is connected. Optionally, for cyber security reasons, the WLAN can be permanently disabled via configuration.
<p>Default SSID and WLAN password: Scan the QR code. It will display something like WIFI:S:PXC5.E003_0000550;T:WPA;P:1400052738;; Then SSID = PXC5.E003_0000550 and password = 1400052738 Determine manually: Use the information from the Date/Series/SN block It will display something like: Date/Series: 20190423A0000550 S/N: 1400052738 SSID = <ASN>_<Running number after the series letter> and password = <S/N></p>	

M-bus manager with integrated power supply	
Interface type	M-bus manager according to EN 13757-2 for max. 7.5 mA, galvanically isolated Max. 4 M-bus meters as subordinates (4 simple M-bus loads à 1.5 mA)
Baud rate	300, 2400 (default), 9600. The maximum baud rate is depending on M-bus device configuration and M-bus repeater.
Cabling (in-house cabling only) Cable length	2-wire cable, interchangeable according to M-bus standard Max. 100 m (330 ft)
Protection	Short-circuit proof Protection against faulty wiring with AC 24 V and DC 24 V
M-bus level converter used as repeater (optional) to extend number of connected M-bus-S devices	Configuration examples (simple M-bus loads à 1.5 mA): <ul style="list-style-type: none"> Up to 60 M-bus-S devices: WTV531-GA5060 Up to 250 M-bus-S devices: WTX631.GA0090

ABT Site checks the number of data points and not the number of M-bus-S devices. The max. number of devices per network depends on the individual load of each device and the given power supply by the M-bus manager (PXC4/5/7) or converter.

KNX PL-Link interface	
Type	KNX TP1 PL-Link, galvanic isolation Baud rate: 9.6 kbps
Cabling (in-house cabling only) Cable length	2-wire cable, 0.75 mm ² / AWG20 or 1 mm ² / AWG18 With internal supply: Max. 80 m (262 ft) With external supply: Max. 1000 m (3300 ft)
Internal bus power	Max. 50 mA When using external bus power for KNX PL-Link, switch off the internal bus power via the ABT Site Tool.

Conformity

Ambient conditions and protection classification	
Classification as per EN 60730 Automatic action Control function Pollution degree Overvoltage category	Type 1 Class A 2 I
Protection against electric shock	Protection class III
Protection degree of housing to EN 60529 Front parts in DIN cut-out Terminal part	IP30 IP20
Climatic ambient conditions <ul style="list-style-type: none"> Storage / Transport (packaged for transport) as per IEC EN 60721-3-2 Operation as per IEC/EN 60721-3-3 	<ul style="list-style-type: none"> Class 1K22 / 2K12 Temperature -25...70 °C (-13...158 °F) Air humidity 5...95 % (non-condensing) Class 3K23 Operation in enclosed dry locations, having no temperature or humidity control Temperature -5...50 °C (23...122 °F) <i>(for details see chapter Mounting)</i> Air humidity 5...95 % (non-condensing)
Mechanical ambient conditions <ul style="list-style-type: none"> Transport per IEC/EN 60721-3-2 Operation as per IEC/EN 60721-3-3 	<ul style="list-style-type: none"> Class 2M4 Class 3M11

Standards, directives, and approvals	
Product standards	IEC/EN 60730-1, IEC/EN 62368-1
Product family standard	IEC/EN 63044-x
Electromagnetic compatibility (EMC)	For residential, commercial, and industrial environments
EU conformity (CE)	See CE declaration ¹⁾
EAC conformity	Eurasian compliance
RCM conformity	See RCM declaration ¹⁾
UL/cUL approbation (US / Canada)	UL916, http://ul.com/database UL94, housing material meets classification V-0 ²⁾
CSA certification	C22.2, http://csagroup.org/services-industries/product-listing
FCC	CFR 47 Part 15C
BACnet	Profile: B-BC Revision: 1.16 Detailed information on BACnet certificates, BTL listings, and PICS can be found on the BACnet website (filtered for Siemens products)
AMEV profile (BACnet 2017)	AS-A / AS-B
KBOB profile (BACnet 2017)	AS-CH ³⁾
Environmental compatibility ¹⁾	The product environmental declaration ¹⁾ contains data on environmentally compatible product design and assessments (RoHS compliance, materials composition, packaging, environmental benefit, disposal).
OSHPD seismic certification	Product meets OSHPD Special Seismic Certification Preapproval (OSH-0217) under California Building Code 2022 (CBC 2022) ⁴⁾

¹⁾ Documents can be downloaded at www.siemens.com/bt/download.

²⁾ Material level

³⁾ AS-CH pending

⁴⁾ When installed within the following Siemens enclosures: PXA-ENC18, PXA-ENC19, or PXA-ENC34.

European Union conformity

Contact for regulatory topics: (EU) Siemens AG, Berliner Ring 23, DE-76437 Rastatt

FCC Statement

This equipment has been tested and found to comply with the limits for a Class B digital device, pursuant to part 15 of the FCC Rules. These limits are designed to provide reasonable protection against harmful interference in a residential installation. This equipment generates, uses and can radiate radio frequency energy and, if not installed and used in accordance with the instructions, may cause harmful interference to radio communications. However, there is no guarantee that interference will not occur in a particular installation. If this equipment does cause harmful interference to radio or television reception, which can be determined by turning the equipment off and on, the user is encouraged to try to correct the interference by one or more of the following measures:

- Reorient or relocate the receiving antenna.
- Increase the separation between the equipment and receiver.
- Connect the equipment into an outlet on a circuit different from that to which the receiver is connected.
- Consult the dealer or an experienced radio/TV technician for help.

This device complies with Part 15 of the FCC rules. Operation is subject to the following two conditions:

1. This device may not cause harmful interference, and
2. this device must accept any interference received, including interference that may cause undesired operation

FCC Caution: Changes or modifications not expressly approved by Siemens Switzerland Ltd. could void user authority to operate the equipment. United States representative <https://new.siemens.com/us/en/products/buildingtechnologies/home.html>

Industry Canada statement

This device complies with ISED's license-exempt RSSs. Operation is subject to the following two conditions:

1. This device may not cause interference, and
2. This device must accept any interference received, including interference that may cause undesired operation.

Radiofrequency radiation exposure statement

This equipment complies with FCC and IC radiation exposure limits set forth for an uncontrolled environment. This equipment should be installed and operated with a minimum distance of 20 cm between the radiator and your body.

This transmitter must not be co-located or operated in conjunction with any other antenna or transmitter.

Housing

Color top / bottom	2003 Ti-Grey / 804 Black
Dimensions	per DIN 43880, see Dimensions
Weight without / with packaging	351 g / 391 g

Connection terminals

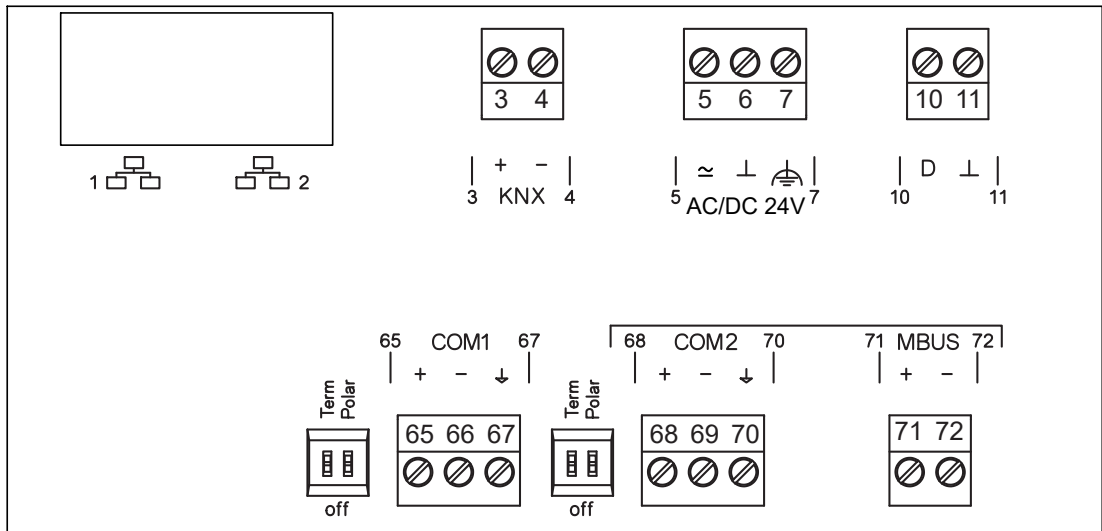

Terminal	Symbol	Description
1, 2		2 x RJ45 interface for Ethernet with switch
3, 4	KNX	KNX PL-Link
5, 6	≈, ⊥	Operating voltage AC 24 V or DC 24 V
7		Functional ground (must be connected on the installation side with the building grounding system (PE)).
10, 11	D, ⊥	Digital input
Term	on, off	Switch for bus termination
Polar	on, off	Switch for polarization
65, 66, 67	COM1	Interface EIA-485 (M-bus, Modbus RTU, BACnet MS/TP)
68, 69, 70	COM2	
71, 72	MBUS	M-bus interface

Dimensions

All dimensions in mm and inches.

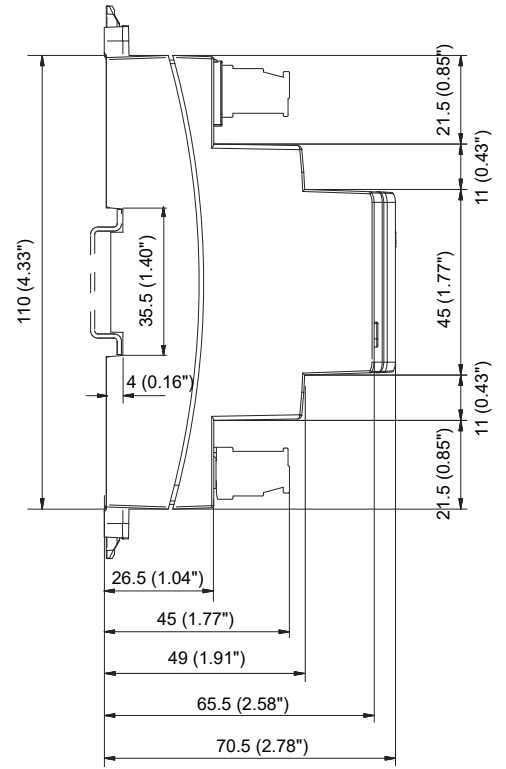
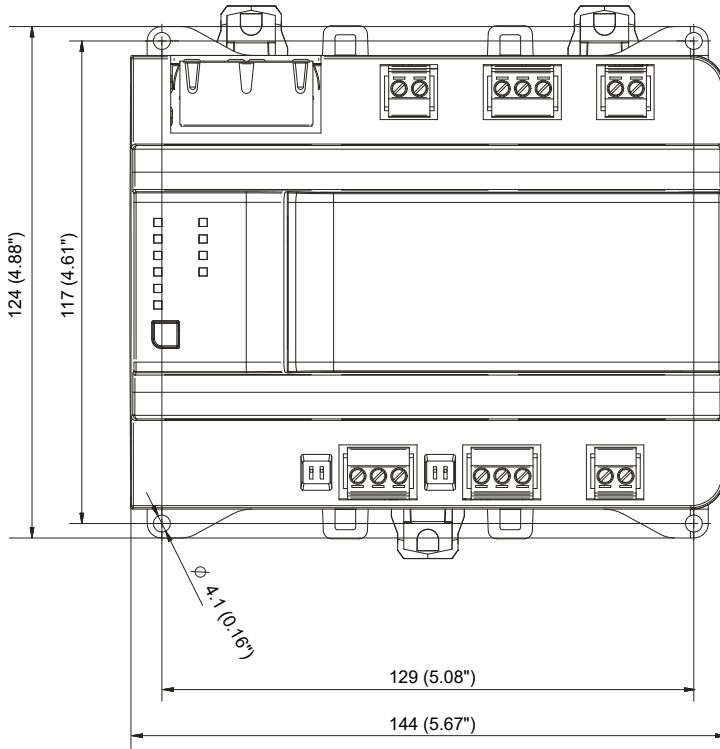

Issued by
Siemens Switzerland Ltd
Smart Infrastructure
Global Headquarters
Theilerstrasse 1a
CH-6300 Zug
+41 58 724 2424
www.siemens.com/buildingtechnologies

© Siemens 2020
Technical specifications and availability subject to change without notice.

Document ID A6V11646020_en--_j
Edition 2024-02-02